



# HEAVY DUTY SPRA-COUPÉ<sup>®</sup> CENTRIFUGAL PUMP

FMC-CW-150-MAG-DX3



Maximize the reliability and durability of your Spracoupe with an Ace Heavy Duty Centrifugal Pump. This powerful design delivers superior performance with minimal maintenance, when compared to its closest industry competitors. Ace Pumps' precision craftsmanship ensures the pump's dependability and longevity.

©Spracoupe is a registered trademark of AGCO Corporation.

Pump advantages include:

- Fits Spracoupe Models 3430, 3440, 3630, 3640, 4440, 4640
- Heavy Duty 204 Bearings - 66% More Dynamic Load Capacity Than Original Equipment
- Ultra-Durable Double Bearing Clutch - 93% Higher Torque Rating Than Original Equipment
- Optional Severe Duty Controlled Porosity Silicon Carbide Seal
- 3/4" Pump Shaft

Pump Feature	Ace Replacement	Original Equipment
Pump Bearings	<b>204 Heavy Duty</b>	202
Pump Shaft	<b>3/4" Diameter</b>	5/8" Diameter
Clutch Rating	<b>58 ft. lbs.</b>	30 ft. lbs.
Clutch Bearings	<b>Two</b>	One
Clutch Pulley	<b>Machined Steel</b>	Stamped Steel

[www.AcePumps.com](http://www.AcePumps.com)  
 901-948-8514 • 1650 Channel Avenue  
 Memphis, TN 38113

To determine the appropriate horsepower requirements for your application at a given flow and pressure:

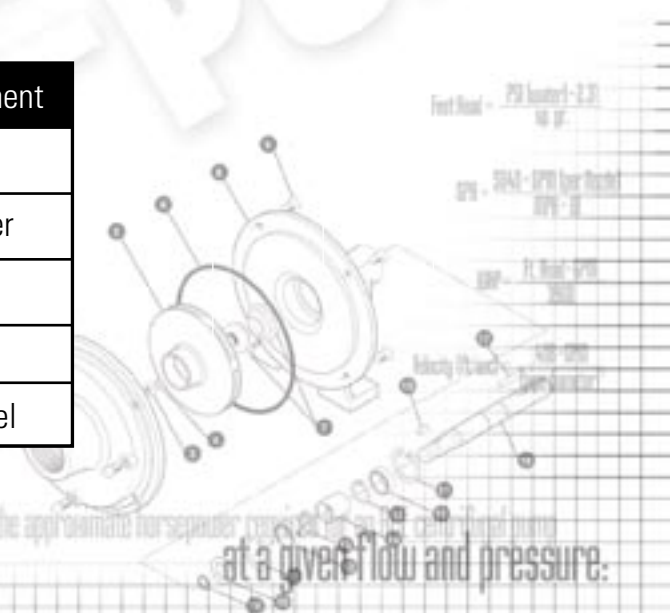



## DIMENSION DRAWING

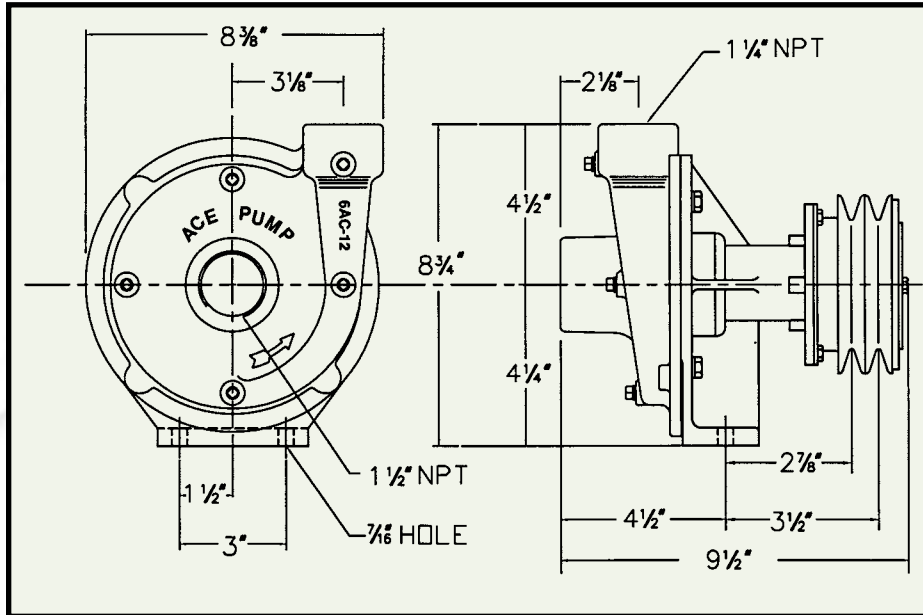

## PERFORMANCE GRAPH

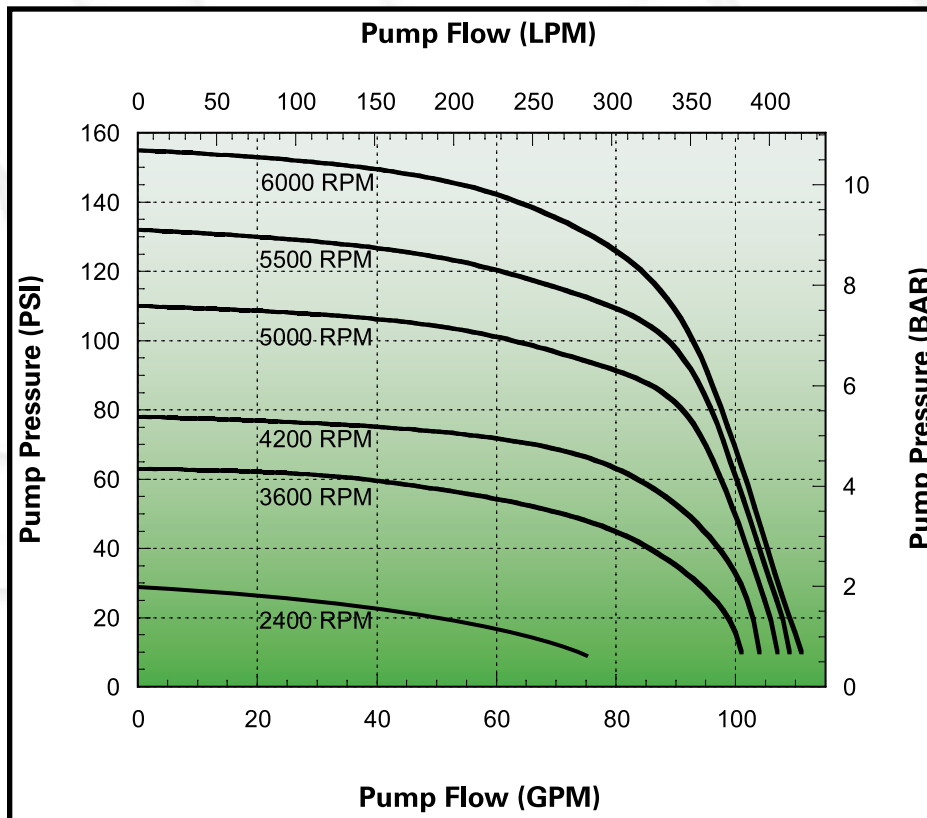

[www.AcePumps.com](http://www.AcePumps.com)  
 901-948-8514 • 1650 Channel Avenue  
 Memphis, TN 38113

at a given flow and pressure.