



High Performance Gas Engine Driven Centrifugal Pump

GE-860

- Suction 2" Discharge 1-1/2"
- Maximum Pressure 140 PSI and Maximum Flow 140 GPM
- Impeller attaches directly to 1" keyed shaft on 8 to 10 HP engines
- Large vent area between pump and engine
- Optional electric start engine
- Available Complete or Less Engine

GE-860-LE Less Engine
 GE-860-HONDA Pull start
 GE-860-HONDA-ES Electric start



PERFORMANCE CHART

ENGINE SHAFT SPEED*	20	40	60	80	100	120	140
	PSI	PSI	PSI	PSI	PSI	PSI	PSI
	GPM	GPM	GPM	GPM	GPM	GPM	GPM
3800 RPM	140	120	103	80	60	40	5
3400 RPM	140	120	95	70	32	-	-
3000 RPM	140	110	70	15	-	-	-

* Engine shaft speed at shut-off.
 Performance data of pump equipped with 8 HP Honda.

DIMENSIONS

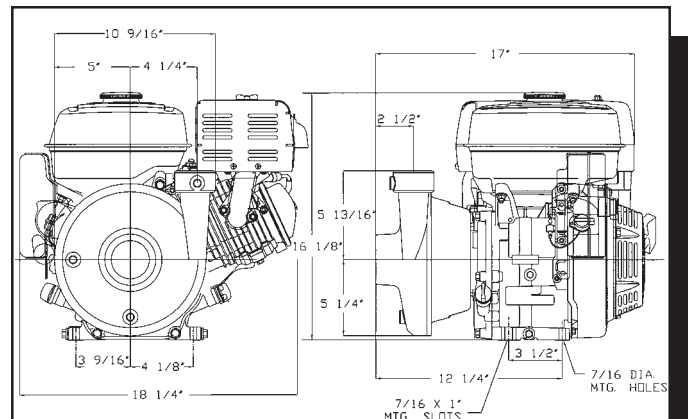

Note: GE-860-HONDA pictured. Dimensions may vary depending on make and size of engine. Use only for Reference

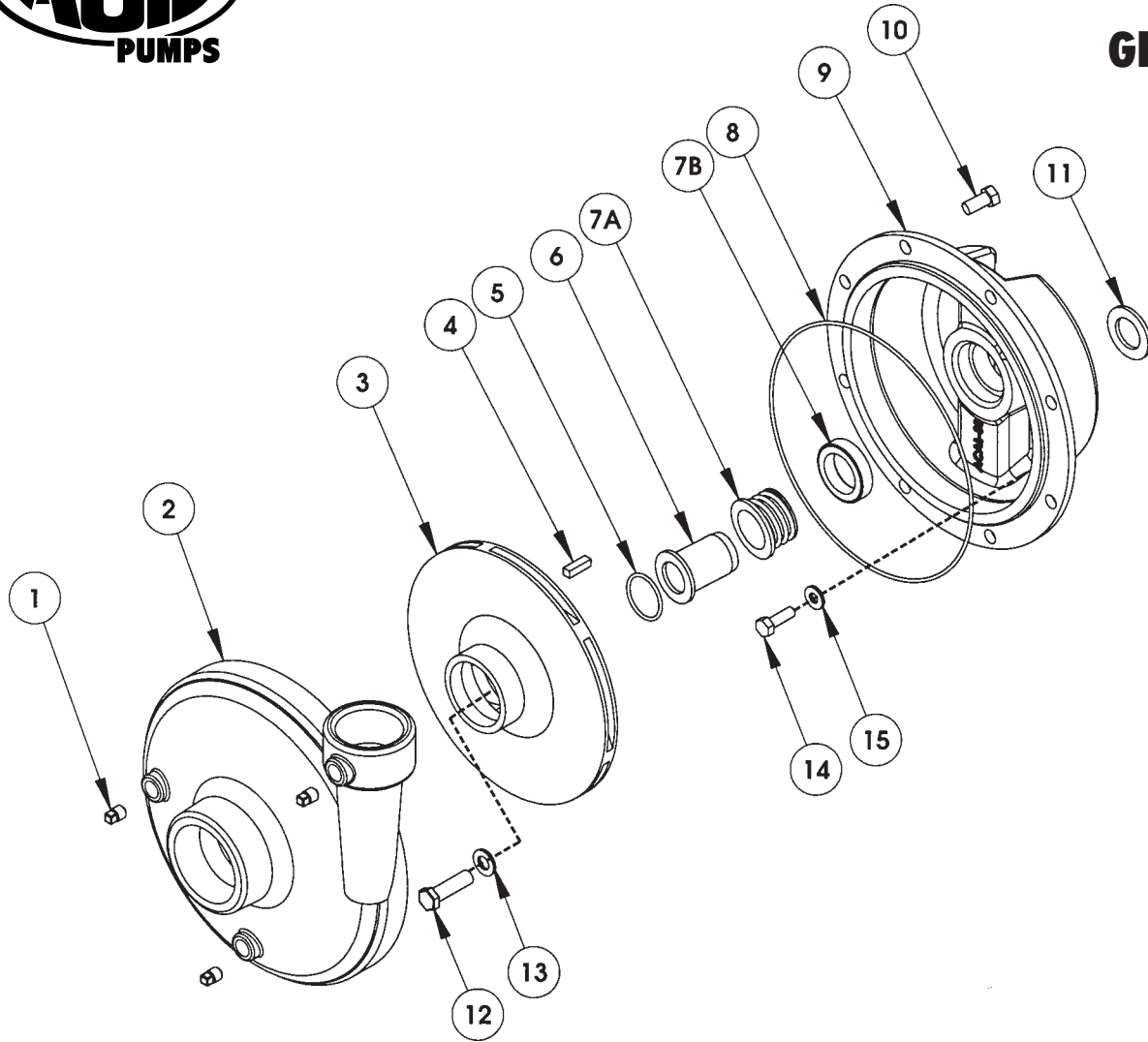

REF. #	PART NUMBER	EDP #	DESCRIPTION	REQ.
1	BAC-53	41110	Pipe plug, 1/8" NPT	3
1	41120	41120	Pipe plug, 1/8" NPT, stainless steel (optional)	3
2	ACAL-14	30160	Volute, 2" x 1-1/2", cast iron	1
3	ACAL-26-860	30558	Impeller, GE-860, cast iron with keyway	1
4	41083	41083	Key, 1/4" x 1/4" x 7/8"	1
*5	41865	41865	"O" Ring, impeller	1
6	42108	42108	Shaft sleeve, GE-860, stainless steel	1
*7	TYPE 21-1.250-V60	30267	Seal, 1.25" Type 21 mechanical seal, Viton	1
*8	ACAL-4	30009	"O" Ring gasket for ACAL-14 volute	1
9	ACAL-88	30187	Bracket, cast iron	1
10	40950	40950	Cap screw, 3/8" NC x 3/4"	8
10	40930	40930	Cap screw, 3/8" NC x 3/4", stainless steel (optional)	8
11	GE-54	42220	Slinger, 1" ID x 1-5/8" OD x 1/8"	1
12	30022	30022	Cap screw, 7/16"-20 UNF x 1-1/2", stainless steel	1
*13	30023	30023	Washer, 7/16" sealing	1
14	GE-60-SS	42235	Cap screw, 5/16" NF x 3/4" , stainless steel	4
*15	30028	30028	Washer, 5/16" sealing, stainless steel	4
#	42072	42072	Gas engine, 8 HP Honda, pull start, GX240K1QA2	1
#	42067	42067	Gas engine, 8 HP Honda, electric start, GX240K1QAE2	1
#	RK-GE-860/1660	61010	Repair kit for GE-860	1

* Items included in pump repair kit.



GE-860-LE ASSEMBLY INSTRUCTIONS

The -LE pump kit includes all parts necessary to assemble the pump on a gas engine with 1" keyed shaft.

Assembly:

1) Remove box contents and verify all parts were received. The following parts are factory installed prior to shipment: a) the 41083 key is in the impeller hub, b) the stationary seal face is in the bracket, and c) the rotating seal face and spring are on the shaft sleeve.

2) Install the GE-54 slinger around the engine shaft and push to the shaft shoulder.

3) Place the ACAL-88 pump bracket carefully over the engine shaft. Install the bracket with the vent channel top to bottom for proper drainage in case of a seal leak. Verify the slinger is on the shaft with clearance in front and back for proper function.

5) Attach the ACAL-88 bracket to engine with (4) GE-60-SS 5/16" cap screws and (4) 30028 5/16" sealing washers. The rubber side of the washer goes against the ACAL-88 bracket. Torque bolts to 12 foot pounds.

Caution: Aluminum engine housing threads may strip if over tightened.

6) Apply antiseize compound on the engine shaft and keyway.

7) Install the shaft sleeve-seal assembly over the shaft with the flange away from the engine.

Caution: Be careful not to touch or contaminate the seal face.

8) Install the 41865 O-ring into the groove on the ACAL-26-860 impeller hub (grease the o-ring lightly to hold in place for assembly). Install the ACAL-26-860 impeller over the engine shaft aligning the impeller key with the shaft keyway.

9) Attach impeller with (1) 30022 7/16" cap screw and (1) 30023 7/16" sealing washer with rubber side against the impeller. Apply removable threadlocker (Ex. Loctite 242) to screw threads and torque to 12 foot pounds.

10) Place the ACAL-4 housing seal O-ring onto the ACAL-88 pump bracket around the pilot.

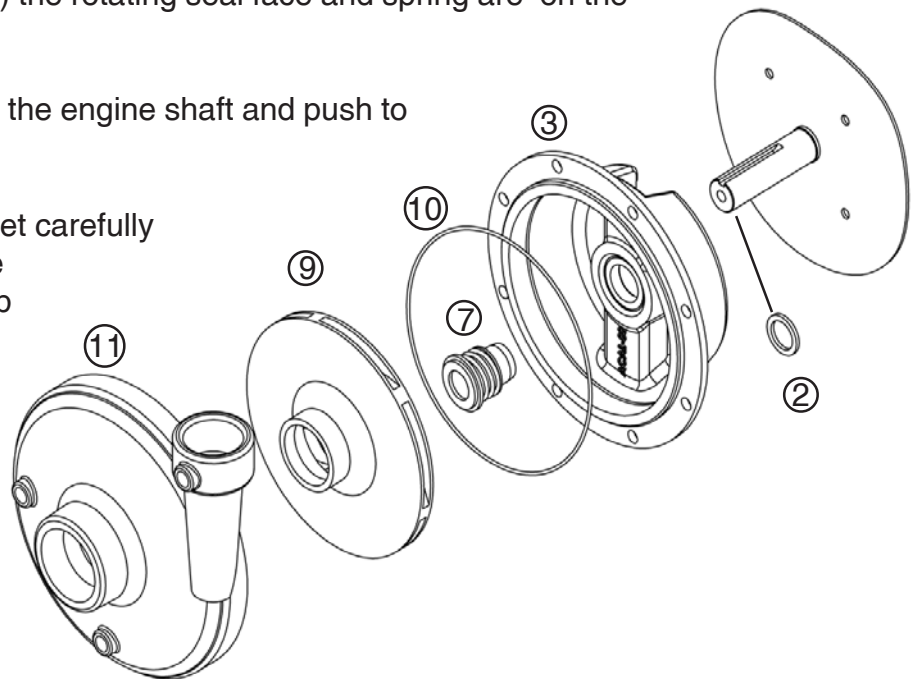



GE-860-LE ASSEMBLY INSTRUCTIONS (CONTINUED)

- 11) Attach ACAL-14 volute to ACAL-88 bracket with (8) 40950 3/8" cap screws. Apply threadlocker or silicon sealer to the bolt threads at the discharge throat to prevent leakage. Tighten bolts to 20 foot pounds of torque.
- 12) Follow the engine manufacturers instructions for engine startup procedures.

SEAL REPLACEMENT INSTRUCTIONS

Disassembly:

- 1) Remove 8) 40950 3/8" cap screws.
- 2) Remove ACAL-14 volute.
- 3) Remove the 30022 7/16" cap screw and 30023 sealing washer from inside the impeller suction port. A screwdriver or file may be placed in an impeller vane to prevent rotation during removal. Discard the used sealing washer.
- 4) Remove the ACAL-26-860 impeller from the shaft. Verify that the key is in place in the impeller keyway. If the key is loose apply silicone and reinstall in the keyway.
- 5) Remove the sleeve-seal assembly from the shaft. Remove the rotating seal face and spring from the shaft sleeve.
- 6) Install the new seal spring and rotating seal face on the shaft sleeve. **Caution:** Be careful not to touch or contaminate the seal face. Water may be placed on the rubber seal components as a lubricant for installation.
- 7) Remove the stationary seal face from the ACAL-88 bracket with a screwdriver and clean the seal bore. Cover the seal face with a clean cloth and press the new stationary seal face into the bracket by hand. **Caution:** Be careful not to contaminate the seal face. Water may be placed on the rubber seal components as a lubricant for installation.
- 8) Refer to the pump assembly instructions on the prior page for re-assembly.