



Polypropylene Gasoline Engine Driven Pump



GE-85

- Barske Tall Blade Impeller Design - Higher Pressures at Standard Engine Speeds
- Suction 1" NPT x Discharge 3/4" NPT
- Maximum Pressure 57 PSI and Maximum Flow 22.5 GPM
- Impeller Attaches Directly to 3/4" Keyed Shaft Engine
- Standard Viton® Carbon/Ceramic seal or Optional Severe Duty Silicon Carbide Mechanical Seal
- All Polypropylene Corrosion Resistant Construction
- Available Models:

GE-85-LE 3 lbs. Less Engine

GESC-85-LE 3 lbs. Less Engine

Viton® is a registered trademark of Dupont Dow Elastomers.
 Honda® is a registered trademark of Honda Motor Company.

PERFORMANCE CHART

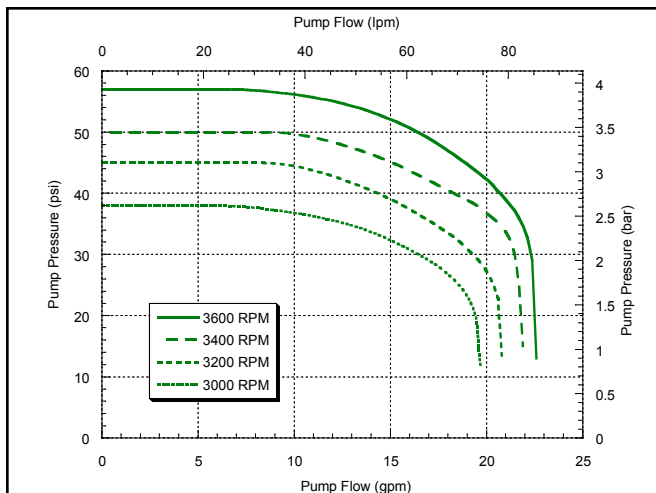

* Engine shaft speed at shut-off.

Performance data of pump mounted on Honda® GC-160.

DIMENSIONS

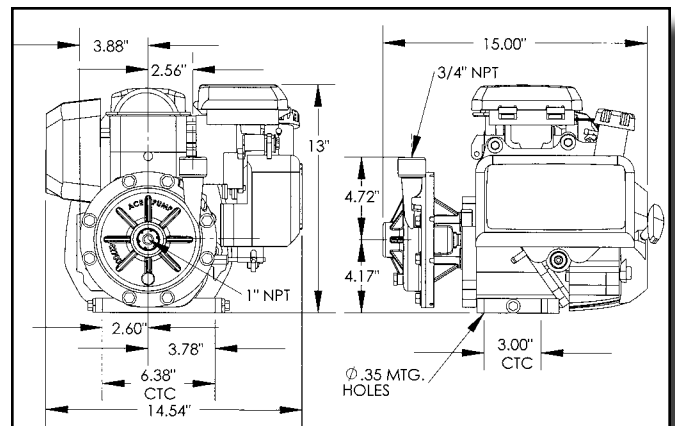

INCHES	15	14.54	13	6.38	4.72	4.17	3.88	3.78	3	2.6	2.56
MM	381.0	369.3	330.2	162.1	119.9	105.9	98.6	96.0	76.2	66.0	65.0

Dimensions of pump mounted on Honda® GC-160.

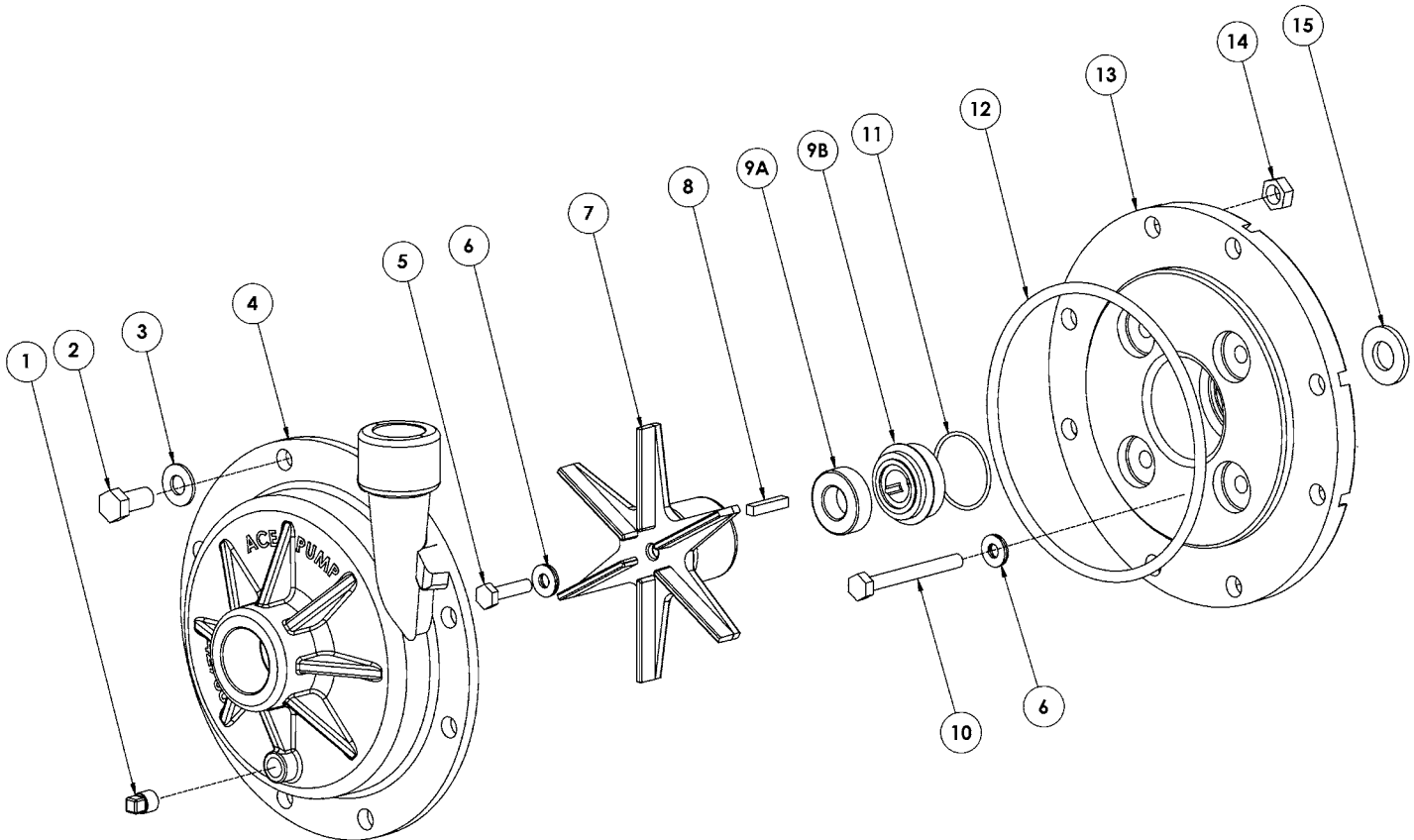

REF. #	PART NUMBER	EDP #	DESCRIPTION	REQ.
1	BAC-53-P	41119	Pipe plug, 1/8" NPT, plastic	1
2	80250	80250	Cap screw, 3/8"-16 x 7/8", hex head	8
3	42701	42701	Washer, 3/8" flat	8
4	GE-12-75	42700	Volute, 3/4" x 1", polypropylene	1
5	GE-60-SS	42235	Cap screw, 5/16"-NF x 3/4", hex, stainless steel	1
6 ^{①②}	30028	30028	Washer, sealing	5
7	GE-26-85	42711	Impeller, with keyway, polypropylene	1
8	41082	41082	Key, 3/16" x 3/16" x 15/16"	1
9 ^①	BAC-7-660V	30225	Seal, 3/4" , Viton® type rubber	1
9 ^②	BAC-7SC-660V	30226	Seal, 3/4" , Carbide/Ceramic/Viton® (optional)	1
10	42245	42245	Cap screw, M8 x 60, stainless steel (GC-160)	4
10	42238	42238	Cap screw, 5/16"NF x 2-1/4", (GX-160)	4
11 ^{①②}	40159	40159	O-ring, shaft seal, GE-85	1
12 ^{①②}	40017	40017	O-ring, volute seal, GE-85	1
13	GE-14-85	42721	Bracket, GE-85, polypropylene	1
14	BAC-45	41010	Nut, hex, 3/8"	8
15	GE-54-660	42222	Slinger	1
①	RK-GE-85	60845	Repair kit for GE-85	-
②	RK-GESC-85	60846	Repair kit for GE-85, silicon carbide seal	-



GE-85-LE ASSEMBLY INSTRUCTIONS

WARNINGS:

Maximum Fluid Temperature - 140° F

Do Not Run With Flow Shutoff For Extended Periods - Running the pump with no flow for extended periods of time will result in excessive heat and pump failure. Running the pump with flow shutoff for more than 5 minutes causes the fluid temperature to rise and melt pump components. A bypass is recommended for low flow applications.

Do Not Run Dry - Seal damage or failure will result from running dry. Impeller damage may also occur if run dry for an extended period.

The GE-85-LE pump kit includes all parts necessary to assemble the pump on a gas engine with 3/4" keyed shaft.

Assembly:

- 1) Remove box contents and verify all parts were received. The rotating seal face (Ref. 9A) and 41082 key (Ref. 8) are factory installed in the impeller hub. The stationary seal face (Ref. 9B) and 40159 O-ring (Ref. 11) are factory installed in the bracket.
- 2) Insert the GE-54-660 slinger onto the engine shaft and slide over the keyway to the shaft shoulder.
- 3) Place the GE-14-85 bracket carefully over the engine shaft.
- 4) Attach the GE-14-85 bracket to the engine using either (4) 42245 M8 or (4) 42238 5/16"NF cap screws with (4) 30028 sealing washers. The rubber side of the washer faces the GE-14-85 bracket.

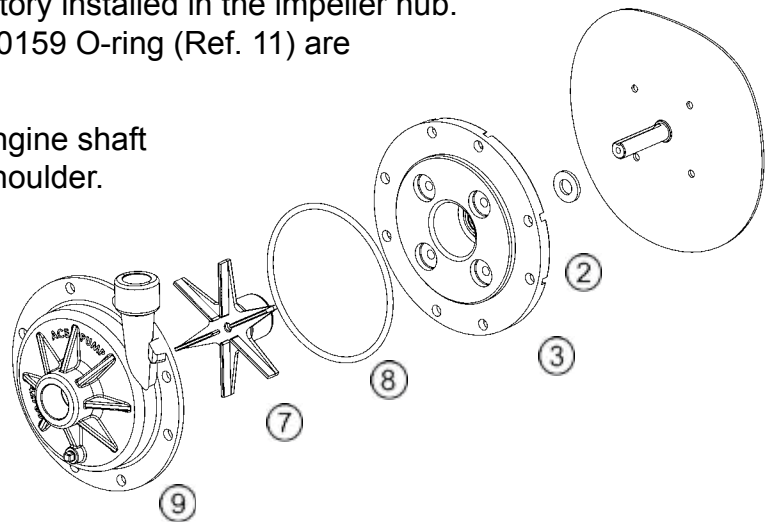

Torque bolts to 10 foot pounds.

Caution: Aluminum engine housing threads may strip if over tightened.

- 5) Verify that the slinger is on the shaft with clearance on both sides for proper function.
- 6) Install the GE-26-85 impeller over the engine shaft, aligning the impeller key with the shaft keyway.
- 7) Attach the impeller with (1) GE-60-SS 5/16" cap screw and (1) 30028 5/16" sealing washer. The rubber side of the sealing washer faces the impeller. Apply removable threadlocker (Ex. Loctite 242 or similar) to screw threads and torque to 5 foot pounds.

ASSEMBLY INSTRUCTIONS CONTINUE ON FOLLOWING PAGE



SEAL REPLACEMENT INSTRUCTIONS

- 8) Lightly grease the 40017 housing seal O-ring and place onto the GE-14-85 pump bracket around the pilot.
- 9) Install the GE-12-75 volute to the GE-14-85 bracket with (8) 80250 3/8" cap screws, (8) 42701 3/8" washers and (8) BAC-45 3/8" hex nuts. Start all bolts first then tighten opposing bolts until all are tightened to approximately 12 foot pounds of torque.
- 10) Follow engine manufacturers instructions for engine startup procedures.

Disassembly:

- 1) Remove (8) 80250 3/8" volute cap screws, (8) 3/8" washers and (8) BAC-45 3/8" nuts.
- 2) Remove GE-12-75 volute and 40017 volute O-ring.
- 3) Remove the GE-60-SS 5/16" cap screw and 30028 sealing washer from the end of the engine shaft. Discard the used sealing washer.
- 4) Remove the GE-26-85 impeller from the engine shaft.
- 5) Remove and discard the rotating seal face and rubber cup from the impeller hub by prying with a screwdriver inside the seal ID. Keep the 41082 impeller key for reassembly.
- 6) Clean the impeller seal bore prior to installing the new seal. Wet the rubber cup with water to lubricate the seal for installation. Place a clean, non-abrasive cloth over the seal face to prevent damage during installation. Use your hand to press the seal into the bore until it is seated flat.
- 7) Remove the GE-14-85 bracket from the engine by removing (4) 42245 or 42238 cap screws and (4) 30028 sealing washers. Discard the used sealing washers.
- 8) Turn the bracket over and press or tap out the stationary seal and 40159 O-ring.
- 9) Clean the seal bore. Install the new 40159 O-ring under the seal cup on the new stationary seal. Press or tap the seal cup evenly into the seal bore with a 1-1/2" pipe nipple.
Caution: Be careful not to touch or contaminate the seal face.
- 10) Refer to the pump assembly instructions on the previous page for re-assembly.