

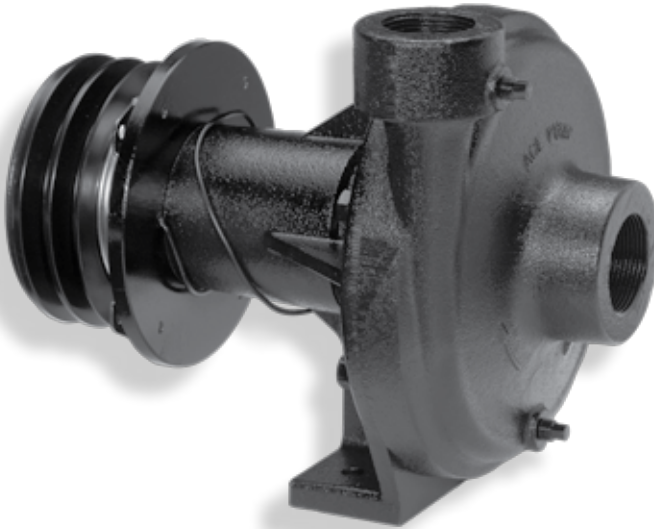

# High Performance Magnetic Clutch Driven Centrifugal Pump

## FMC-650-MAG-D



- Suction 1-1/2" NPT - Discharge 1-1/4" NPT
- Maximum Flow 140 GPM (530 LPM) at up to 120 PSI (8.3 BAR)
- Maximum Pressure 160 PSI (11 BAR) at 4700 RPM
- Modified Impeller Design - Higher Pressure at Lower RPM
- Durable E-Coating Inside and Out for Excellent Corrosion Resistance
- Oversized Bearings for Extended Life
- 5" Solid Steel Dual Belt Pulley for Single or Double Belts
- Heavy Duty 12 Volt DC Magnetic Clutch Transmits up to 44 HP at 4000 RPM
- Counterclockwise Rotation when Facing Pulley End



### Performance Chart

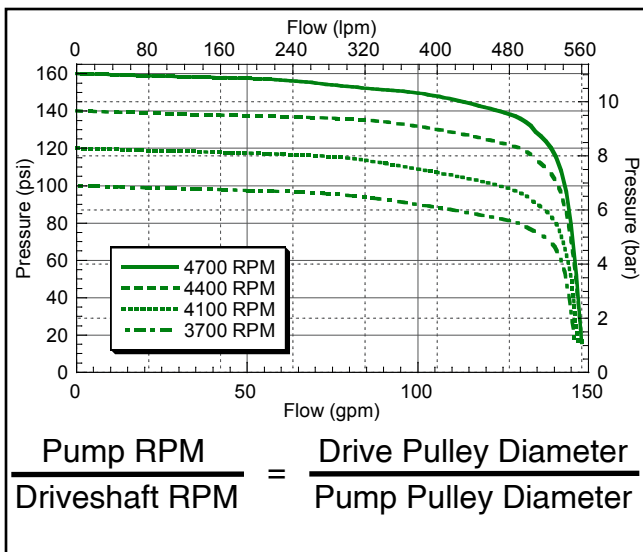

### Dimensions

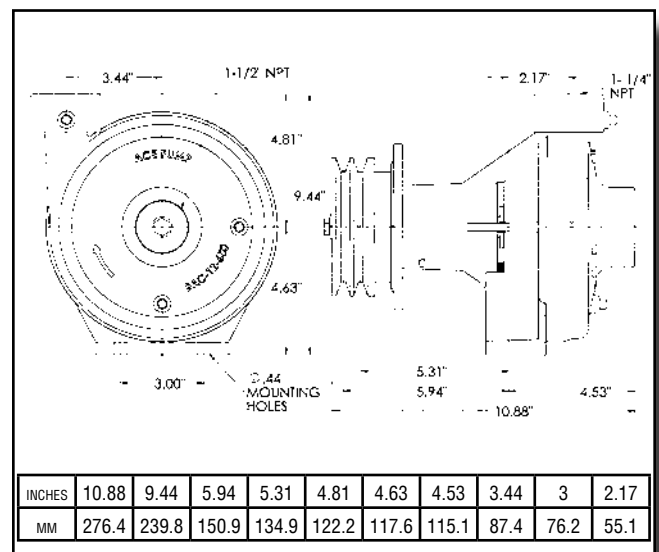

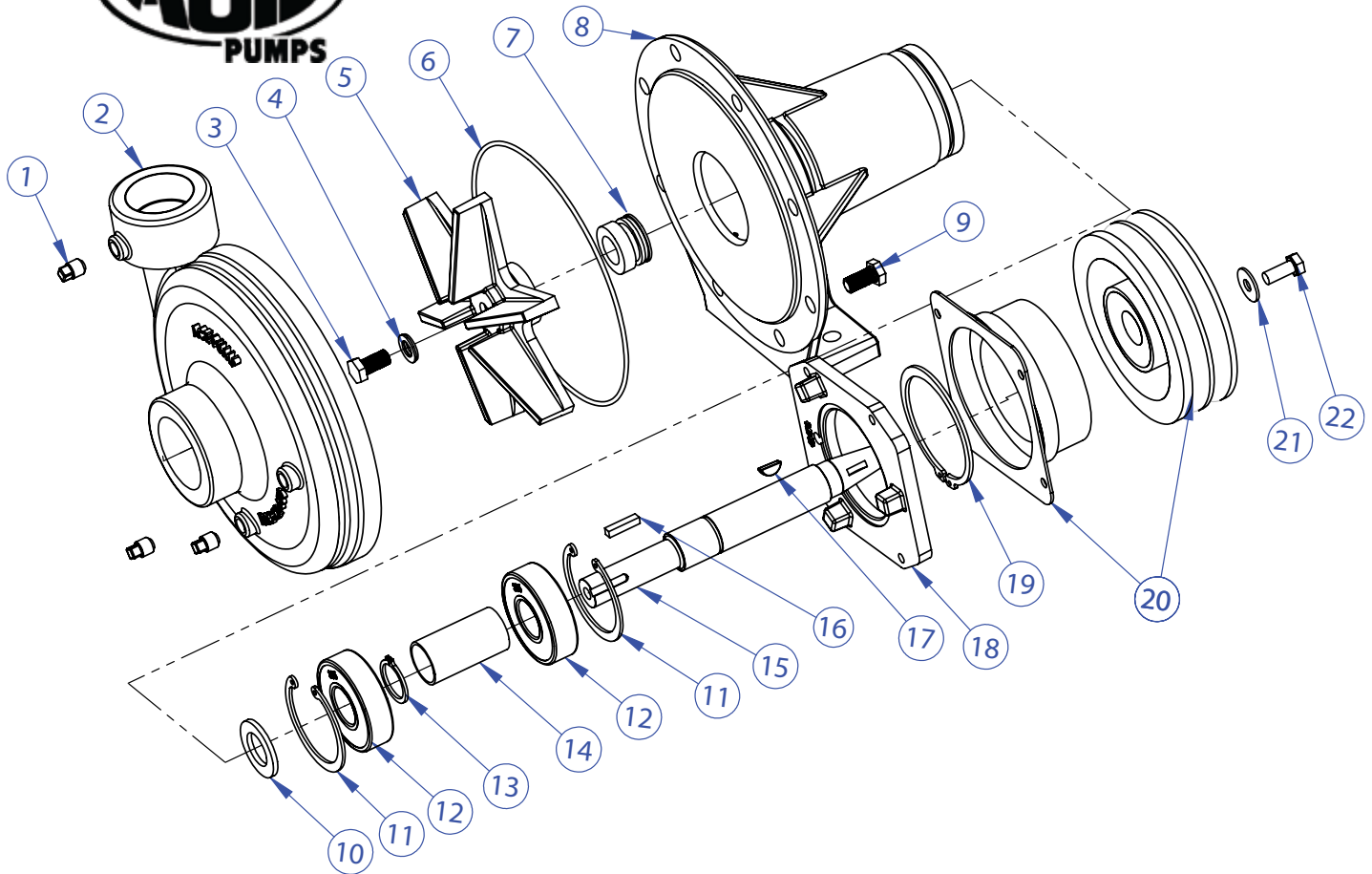

REF. #	PART NUMBER	EDP #	DESCRIPTION	REQ.
1	BAC-53	41110	Pipe plug, 1/8" NPT	3
2	BAC-12-650	30163	Volute, 1-1/2" x 1-1/4" CCW rotation, cast iron, e-coated	1
3	40930	40930	Cap screw, 3/8" NC x 3/4" Hex Head Stainless Steel	1
4 <sup>①②</sup>	30029	30029	Washer, 3/8" stainless steel sealing	1
5	BAC-26-650	30169	Impeller, cast iron, e-coated	1
6 <sup>①②</sup>	BAC-4-150	40015	"O" Ring for BAC-12-650 volute seal	1
7 <sup>①</sup>	BAC-7-650	40145	Seal, carbon/ceramic/Viton®	1
7 <sup>②</sup>	BAC-7SC-650	40146	Seal, silicon carbide mechanical seal (optional)	1
7	BAC-7-650B	40144	Seal, carbon/ceramic/Buna mechanical seal (optional)	1
8	BAC-14-650-MAG	40297	Mounting frame, cast iron, e-coated	1
9	40950	40950	Cap screw, 3/8" NC x 3/4" Hex Head	8
10	BAC-54-650	41132	Slinger	1
11	41943	41943	Snap ring, internal, BAC-14-650	2
12	40875	40875	Bearing, BAC-6-650-D-SS driven shaft	2
13	ACAL-32	30174	Snap ring, external, BAC-6-650-D-SS	1
14	BAC-32-650	40794	Spacer for BAC-6-650-D-SS	1
15	BAC-6-650-D-SS	40052	Shaft, 1" driven, -D clutch tapered, stainless steel	1
16	41085	41085	Key, 3/16" x 3/16" x 7/8"	1
17	41088	41088	Key, woodruff, #505	1
18	41474	41474	Adapter plate, -D clutch, 650 models	1
19	41942	41942	Snap ring for adapter plate	1
20	41481	41481	Clutch assembly, dual belt, taper bore	1
21	41494	41494	Washer, -D clutch attachment	1
22	SP-62	42255	Cap screw, 5/16" NF x 1"; -D clutch attachment	1
①	RK-FMC-650	52720	Repair kit for FMC-650 series pumps	-
②	RK-FMCSC-650	52721	Repair kit for FMC-650 series pumps with silicon carbide seal	-

Ace Pump Corporation • P.O. Box 13187 - 1650 Channel Avenue • Memphis, TN 38113  
 www.AcePumps.com • Phone: 90-948-8514 • Fax: 901-774-6147

FMC-650-MAG-D  
 Revised 06-10